



13231 East 166th St.
Cerritos, CA 90703
Phone (562) 802-3488
Fax (562) 802-3391
www.TwinEaglesBBQ.com

INSTALLATION INSTRUCTIONS

MODELS: TEVH-36, TEVH-48 Indoor/Outdoor Ventilation Hoods

**PLEASE READ ENTIRE INSTRUCTION BEFORE PROCEEDING.
INSTALLATIONS MUST COMPLY WITH ALL LOCAL CODES.**

IMPORTANT: Save these Instructions for the Local Electrical Inspector's use.

INSTALLER: Please leave these Installation Instructions with this unit for owner.

OWNER: Please retain these Instructions for future reference

IMPORTANT SAFETY INSTRUCTIONS

WARNING - TO REDUCE THE RISK OF FIRE, ELECTRICAL SHOCK, OR INJURY TO PERSONS, HOODS SHOULD BE INSTALLED WITH VENTILATORS APPROVED FOR USE WITH THE HOOD. SEE TABLE – 1 OF THIS INSTRUCTION FOR APPROVED VENTILATORS.

WARNING - TO REDUCE THE RISK OF FIRE, ELECTRIC SHOCK, OR INJURY TO PERSONS, OBSERVE THE FOLLOWING:

A. Installation work and electrical wiring must be done by qualified person(s) in accordance with all applicable codes & standards including fire-rated construction. **WARNING:** to reduce the risk of fire, use only metal duct work.

B. Sufficient air is needed for proper combustion and exhausting of gases through the flue (chimney) of fuel burning equipment to prevent backdrafting. Follow the heating equipment manufactures guideline and safety standard such as those published by the National Fire Protection Association (NFPA) and the American Society for Heating, Refrigeration and Air Conditioning Engineers (ASHRAE), and the local code authorities.

C. When cutting or drilling into wall or ceiling, do not damage electrical wiring and other hidden utilities.
D. Before servicing or cleaning unit, switch power off at service panel and lock service disconnecting means to prevent power from being switched on accidentally. When the service disconnecting means cannot be locked, securely fasten a prominent warning device, such as a tag, to the service panel.

CAUTION - TO REDUCE THE RISK OF FIRE AND TO PROPERLY EXHAUST AIR, BE SURE TO DUCT AIR OUTSIDE FOR DUCTED FANS – DO NOT VENT EXHAUST AIR INTO SPACE WITHIN WALLS OR CEILING OR INTO ATTICS, CRAWL SPACES OR GARAGES.

Read this instruction completely before starting installation. Planning the complete installation before starting any work is highly recommended. This includes all aspects of the installation including hood location, ducting, electrical requirements, and adequacy of mounting surfaces.

TABLE - 1

Use model TEVI-060I for internal ventilator on 36" and 48" hoods.
Use model TEVI-120I for internal ventilator on 48" hoods only.
Use TEVE-150E for remote ventilator on 36" and 48" hoods.

This hood has been designed to be used with the ventilators shown in Table-1. Before cutting into cabinets, it is necessary to confirm that the correct ventilator is being used. Your dealer should have reviewed your needs prior to your purchase. Be sure you have the correct ventilation system.
CAUTION: to reduce the risk of fire and electrical shock, install this ventilation hood only with blowers specified by Twin Eagles.

DUCTING: Use a minimum 8" round duct for TEVI-060I installations. Use a minimum 10" round duct for TEVI-120I and TEVE-150E. Use #10100 8" - round transition or #10287 10"-round transition from hood to ducting. Other Transition options are available – See your Dealer for details.

SAFETY WARNING:

Turn off power circuit at the service entrance and lockout panel before wiring the range hood.

BACKDRAFT DAMPER: It is recommended that a backdraft damper be used in all installations. In cold weather installations it is necessary to use a backdraft damper to minimize backflow of cold air into room. A non-metallic thermal break should also be used to minimize conduction of outside temperatures through the ductwork. The thermal break should be located as close as possible to where the ducting enters the heated portion of the house.



NOTE: Unit **must** be vented to outside of the building.

Prepare cabinet for mounting the hood per FIG-2. Use furring strips to level cabinet mounting surface with any cabinet trims. If your hoods accepts and you're using dual internal ventilators refer to that instruction section.

Attach and secure the transition to the hood with #6x3/8 sheet metal screws and tape all joints prior to installing the hood. Attach hood to cabinet using #10 wood screws. Holes are located in the back panel and top panel of the hood for mounting. Use a minimum of four #10x3/4 wood screws to mount the hood. Longer screws are required if wall board or other nonstructural surfaces are used between the hood and main mounting surface which should be a minimum of 3/4 "thick. When using rear holes for additional mounting use appropriate anchors if not engaging the wood structure.

HINT: If you find vibration noise is present because of cabinet structure, use additional screws in holes available to increase rigidity.

Connect 120 volt, 60 Hz power through the conduit hole in top of hood, connecting to pigtail in hood junction box, white to white, black to black and connect green ground wire to the power supply ground wire per local codes.

The recommended height from countertop or cooking surface to the bottom edge of the hood is 30 to 36 inches. Hood is recommended for use over domestic gas or

electric appliances. Not recommended for use over solid fuel fired appliances.

After installing the hood, install the internal blower (see FIG-1) unit by positioning the blower onto bracket-A, notched blower bracket will center blower. Rotate into position against hood top and secure with #8 sheet metal screws via bracket-B. To ease assembly you should pre-drive and then remove the #8 screws before installing the blower. If the remote ventilator is used see related instructions. The TEVE-150E ventilator will require revision of some wiring in the hood receptacle box and possible modification of air discharge opening – See TEVE-150E instructions.

NOTE: TEVE-150E requires a 20 AMP Power Supply.

CAUTION: The hood is of sufficient weight that two installers are recommended to prevent injury or damage to the hood in handling.

Turn the power on at the service entrance and check the operation of the controls.

NOTE: be sure that all dampers are operating properly and are free to open.

FIG-1

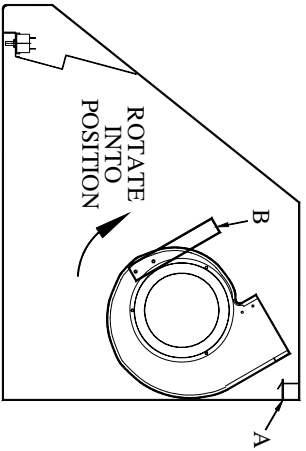

HOOD WIDTH	DIM A
30"/36"	8 3/8
42"	11 1/4
48"/54"	17 1/2
60"	23 1/8

FIG-2

BOTTOM VIEW OF CABINET - FOR MODELS WSL & WCL 30" - 48"
SINGLE VENTILATOR - INTERNAL OR REMOTE

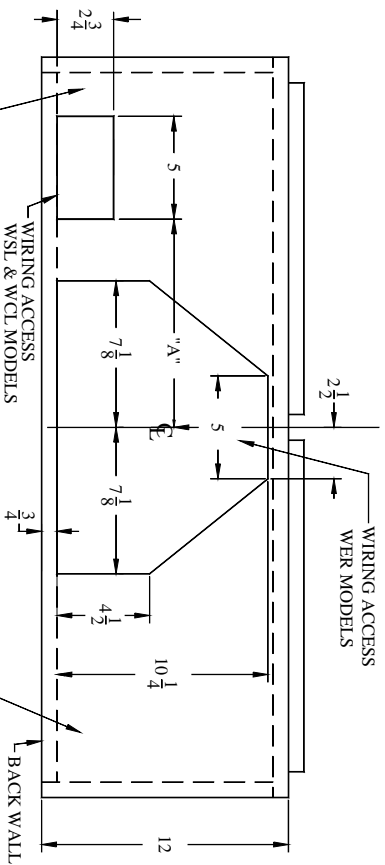
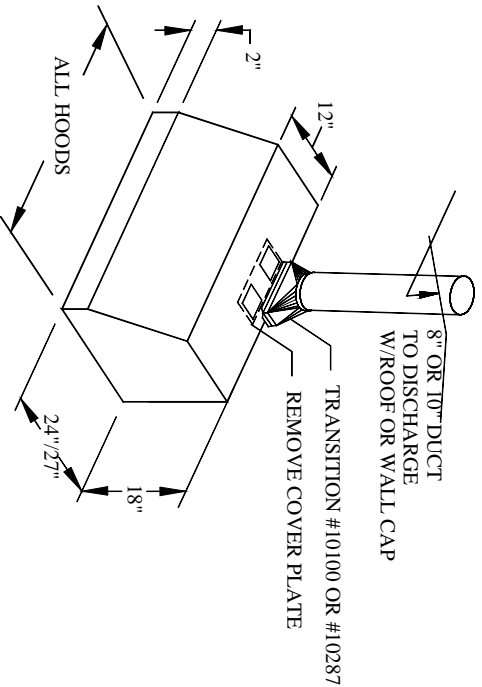

FIG - 4



THE 8" DISCHARGE WITH THE TRANSITION # 10100, OR 10" DISCHARGE WITH TRANSITION # 10287 WILL BE ON THE CENTER LINE OF HOOD WIDTH AND ON CENTER LINE OF 12" DIMENSION

FIG-3

BOTTOM VIEW OF CABINET - FOR MODELS WER36" - 48"

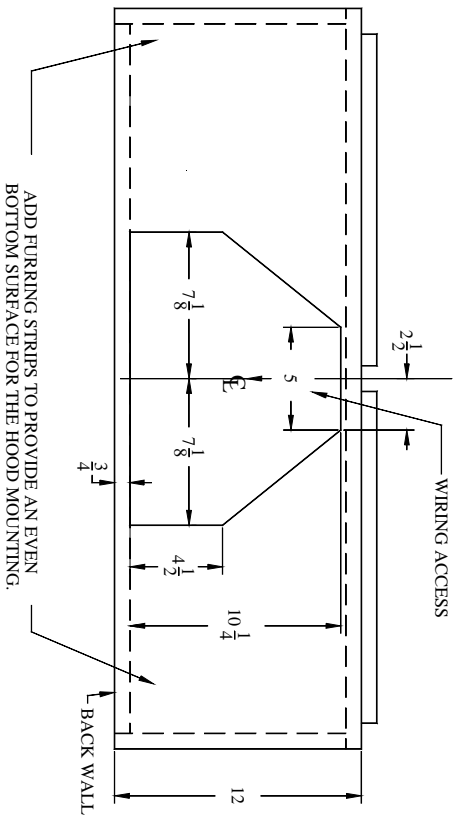

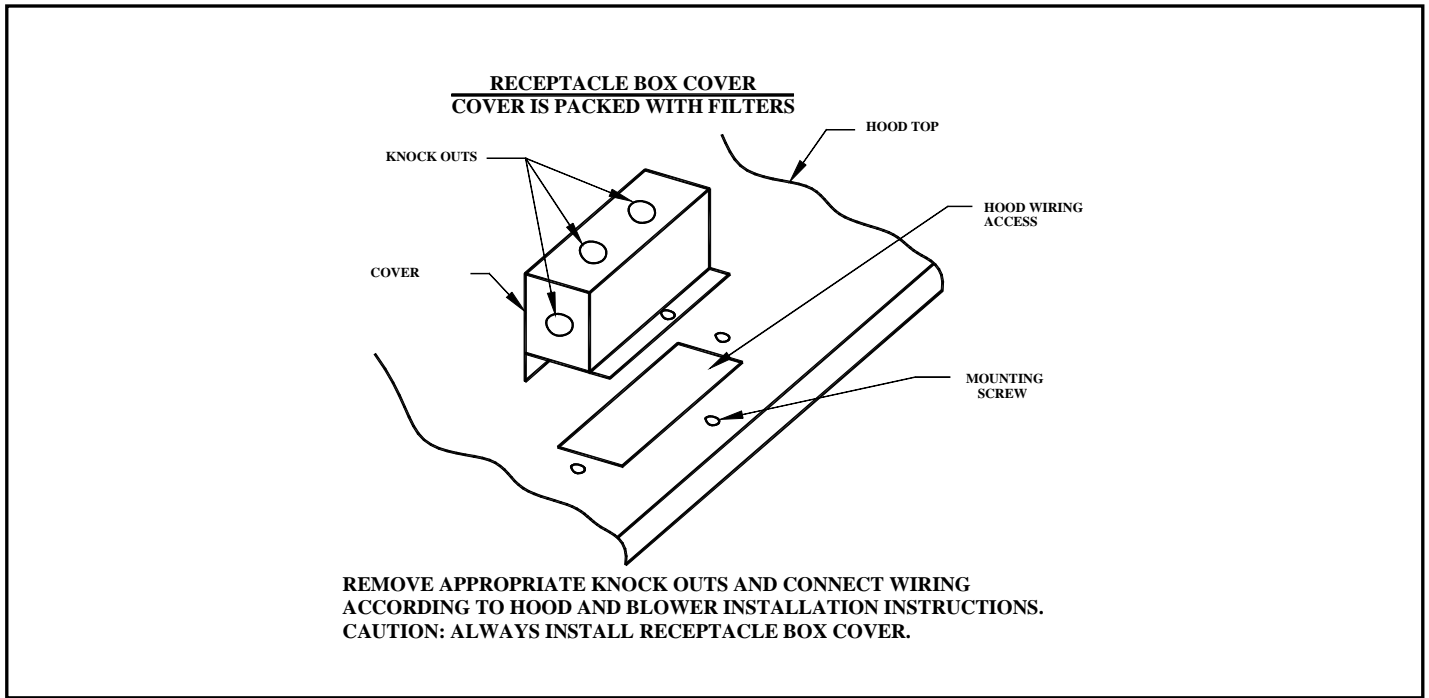

TEVI-120I Dual Internal Ventilators

NOTE: Wiring harness #10220 is included to complete the installation of dual TEVI-120I ventilator

Cabinet Mounting

When using TEVI-120I ventilator the cabinet mounting must accommodate two discharge transitions. Wiring and discharge holes are shown in FIG – 6.

HINT: Transition dimensions may vary. Before assembling transitions to hood, fit them into the prepared cabinet opening to be sure the openings are large enough to accommodate the transition. Enlarge the hole if required.

Hood Preparation

The hood must be prepared for dual ventilator mountings by removing the discharge cover plate and two “breakaway” discharge hole plates. To remove, break the metal webs holding the plate and remove completely. See FIG – 5. Break the metal webs by placing a screwdriver at one corner of the plate and hitting screwdriver sharply with a hammer. After breaking a second web the plate can be flexed to break other webs.

Wear eye protection when using tools.

Attach the transition (See DUCTING, pg 1), obtained separately from your local hardware or available through your dealer, and install the hood as described previously in this instruction.

Ventilator Installation

Install the ventilators as previously described, see FIG – 1 and instruction on same page of this document. Connect the ventilators to the receptacle in the hood junction box using **Harness #10220**. Dress the wires and secure to bracket “A” see FIG – 5, using the wire tie supplied with the harness. Follow the remaining instructions for operating checks to complete the installation.

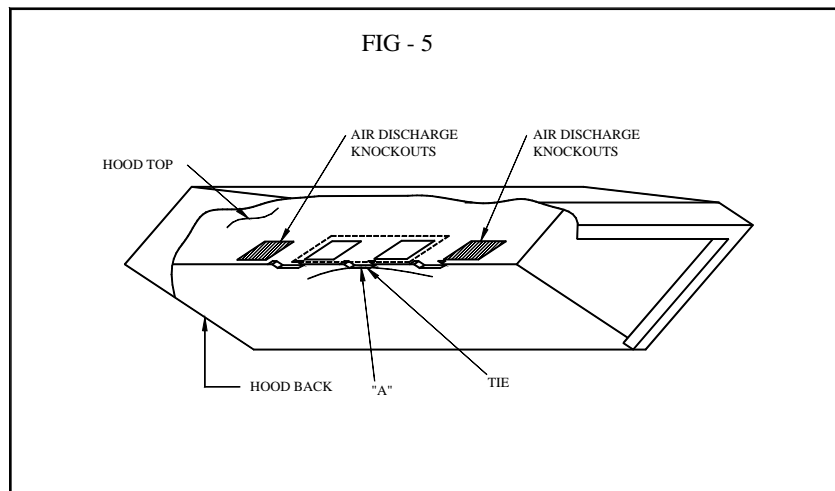

OUTSIDE PATIO OR LANAI INSTALLATION

The Twin Eagles TEVH hoods are approved for installation in an outside patio or lanai area if the area is covered with a protective roof over the hood and installed with a GFCI protected branch circuit. The installation should include an appropriate roof or wall cap on the ventilator discharge to prevent direct exposure of the ventilation duct to precipitation. A typical installation is shown in **FIG - 1**.

Since, outdoor areas are subject to strong cross drafts it is recommended that the hood extend at least 3 – inches, and preferably 6 – inches, over either side of the cooking area to maximize the cooking discharge capture area. Cross drafts will affect the efficiency of the ventilation system and cooking discharge can escape capture by the hood/ventilation system. Be sure to plan for adequate ventilator (blower) capacity to minimize cross drafts influencing the removal of cooking discharges.

Follow the installation instructions properly to ensure all safety procedures and guidelines are adhered to. **NOTE:** Hood is recommended for use over domestic gas or electric appliances. Not recommended for use over solid fuel fired appliances.

