



TWIN EAGLES

U S A

Defining the Art of Outdoor Cooking

Twin Eagles Margarita Center

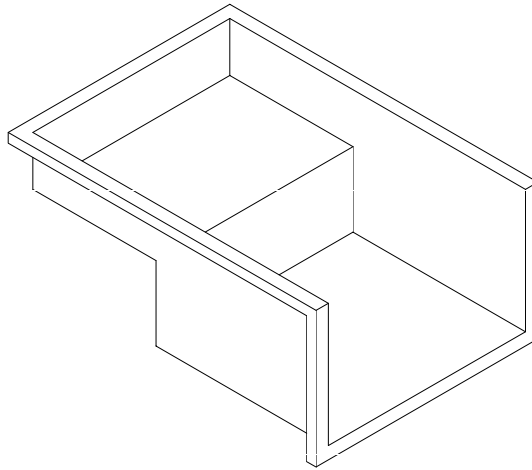

TEM-18

Features:

- ▼ #304 stainless steel construction
- ▼ Superior welding and finish
- ▼ Dual level working space
- ▼ Easily accessible outdoor approved outlet with GFCI
- ▼ Fits TEOB-18 cutout dimensions
- ▼ Easy to use

Specifications:

Overall dimensions

	TEM-18
Height:	: 10.625
Width	: 18.00"
Depth	: 25.00"
Weight	: 21 lbs

Cutout Dimension

	TEM-18
Height	: 9.75"
Width	: 17.50"
Depth	: 24.25